

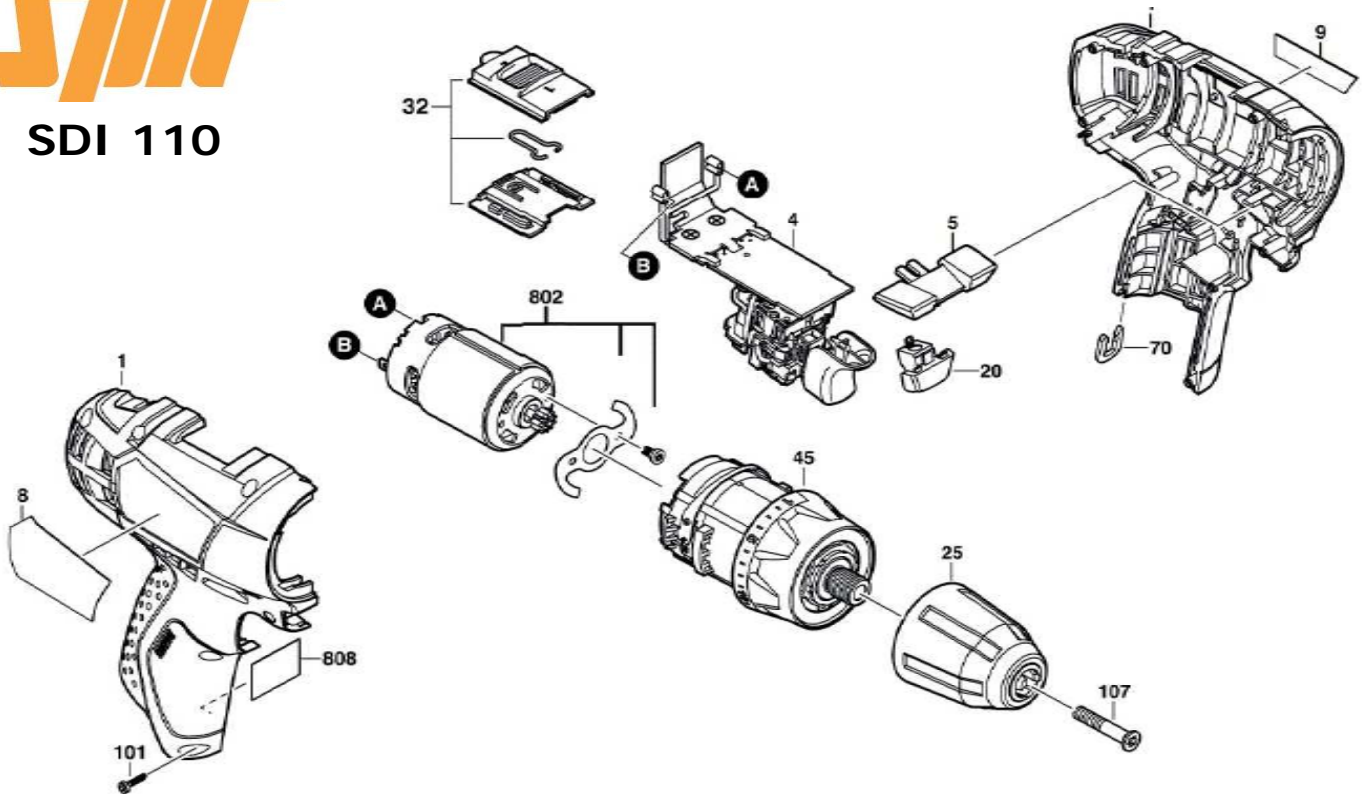



SDI 110



Repère	Code	Désignation	Description
1	652613	Ensemble carter	Housing L.and R
4	652614	Module electronique	Electronic module
5	652615	Commutateur	Change over switch
8	652616	Etiquette latérale D.	label right side
9	652617	Etiquette latérale G.	Label left side
20	652618	Conduite de lumiere	Light guide
25	652495	Mandrin	Chuck
32	652538	Selecteur de vitesse	Regulator
45	652621	Ensemble transmission	Gear
70	652622	Clip	Clip
101	652623	Vis	Screw
107	652498	Vis mandrin M6X30	chuck Screw M6X30
802	652624	Moteur 10,8V	Motor 10,8V