

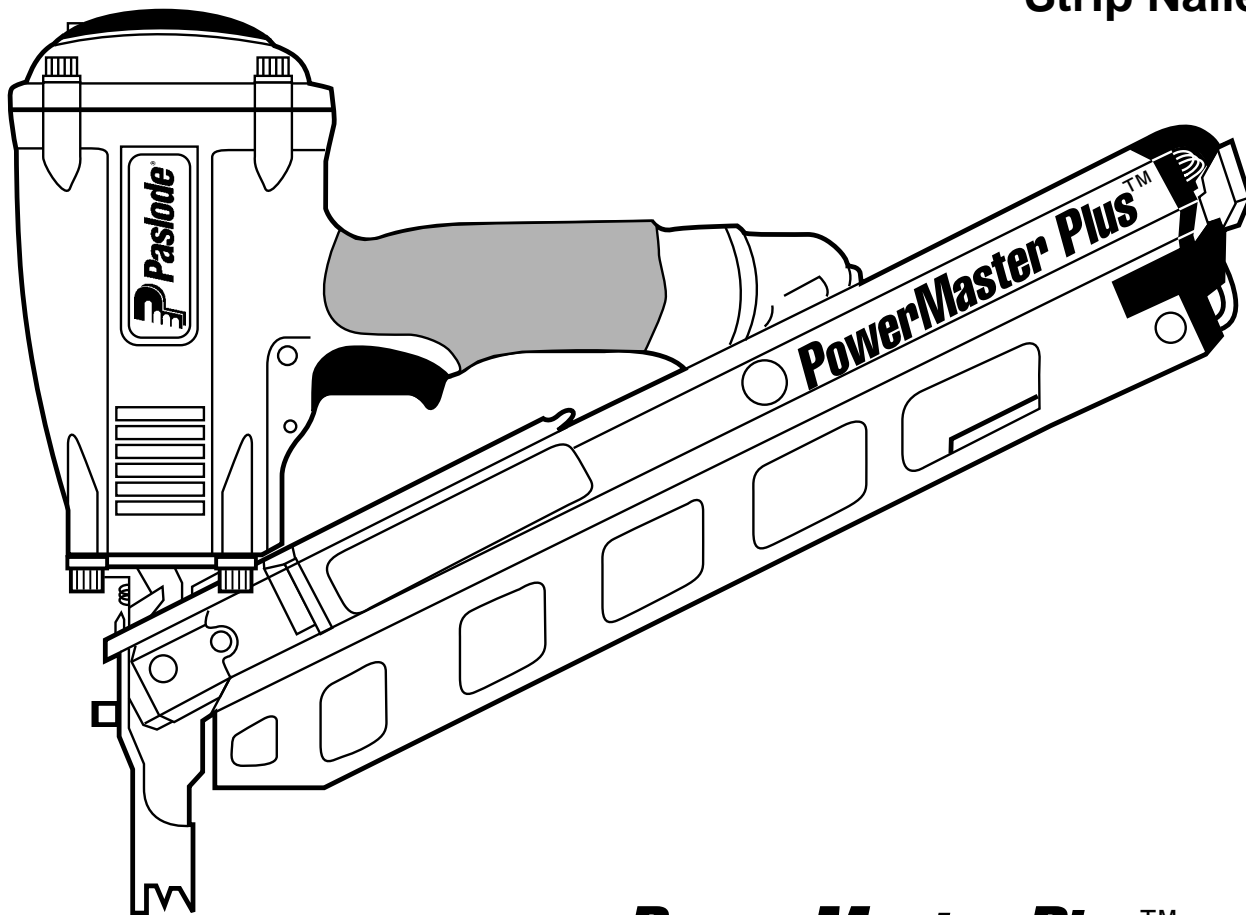

PowerMaster Plus™
MODEL F-350S
Strip Nailer



PowerMaster Plus™

**IMPORTANT!
DO NOT DESTROY**

Always refer to safety and maintenance manual #403606 for detailed information on this tool. It is the customer's responsibility to have all operators and service personnel read and understand this information.

**TOOL SCHEMATIC AND
PARTS**

PARTS LEGEND *PowerMaster Plus*™ F-350S, 501000

▲ 1	501043	1	T.H.S.C.S. 1/4 -20 x 1/2"	38	501008	1	Lever, Bottom Trip
2	501016	1	Air Deflector	39	402668	1	Retaining Ring
3	092735	4	S.H.C.S. 1/4-20 x 1-1/4"	40	097748	1	Spring, Valve Pin
4	092757	4	Flatwasher 1/4"	41	097746	1	Valve Pin
5	501017	1	Cap	42	071297	3	Roll Pin 1/8 x 1-1/8"
*6	500461	1	O-Ring	*43	092174	1	O-Ring, Valve Body
*7	092042	1	O-Ring	44	401958	1	Valve Body
8	500407	1	Spring, Main Valve	46	501052	1	Nose 30°
*9	501001	1	Gasket, Cap	47	095417	4	Lockwasher 5/16
10	406041	1	Retaining Ring	▲48	009016	4	S.H.C.S. 5/16-18 x 1"
11	500455	1	Upper Valve Piston	49	501006	1	Spring, W.C.E.
12	401946	1	Seal, Main Valve	50	501015	1	Upper W.C.E.
*13	091208	1	O-Ring	51	501037	1	Allen Nut, W.C.E.
*14	401950	1	O-Ring	52	501014	1	Lower W.C.E.
15	500456	1	Lower Valve Piston	53	501029	1	Magazine with Wear Strips
16	500454	1	Post	54	500717	1	Nail Cover
*17	095432	2	O-Ring	55	500531	1	Follower
18	500453	1	Bumper, Post	56	501044	1	3/16 Hex Key, Long Arm
19	402906	1	B.H.S.C.S.10-32 x 5/8"	57	501025	1	End Cap, Magazine-RT
*20	092971	1	O-Ring, Piston	58	501024	1	End Cap, Magazine-LF
→■*21	501019	1	Driver Blade	59	501027	1	Latch
22	402011	1	Seal Sleeve	60	501046	1	Drum Pin Assembly
23	501004	1	Sleeve	61	500513	1	Negator Assembly
*24	092235	1	O-Ring, Sleeve	62	500800	1	Nameplate, Global
*25	501002	1	O-Ring	▲63	404904	2	Screw 1/4-28 x 5/8"
*26	500730	1	Bumper	64	500509	1	Front Bracket
27	501020	1	Housing	65	501028	1	Spring, Latch
28	501023	1	Grip, Handle	66	501026	2	S.H.C.S. 8-32 x 2"
29	501018	2	Label, Housing	67	066840	1	S.H.C.S. 8-32 x 3/4"
30	501013	1	End Cap, Housing	68	404414	2	Flatwasher #8
31	500516	1	B.H.S.C.S. - Special	69	404325	2	Stop Nut
32	404274	1	Flatwasher	70	500520	2	Wear Strip
33	500525	1	Locknut, 5/16-24	** 71	500458	1	Warning Label
34	091622	1	Reducing Pipe Bushing	72	501055	2	Logo Label
35	501010	1	Trigger	73	500199	1	Spring, Trigger
36	402669	1	Pin, Trigger	74	500729	1	Blade Seal
37	501009	1	Spirol Pin	→ 75	501003	1	Piston

* Denotes Normal Wear Items

** Make sure Warning Label (Part No. 500458) is properly affixed. Replace if necessary. Label available at no charge through the Service Department.

▲ Apply Loctite 242 (Blue) Part No. 093500

■ Apply Loctite Green Part No. 401491

→ Denotes New Change

⚠ WARNING

All parts must be periodically inspected and replaced if worn or broken. Failure to do this can affect the tool's operation and present a safety hazard.

AIR CONSUMPTION CHART

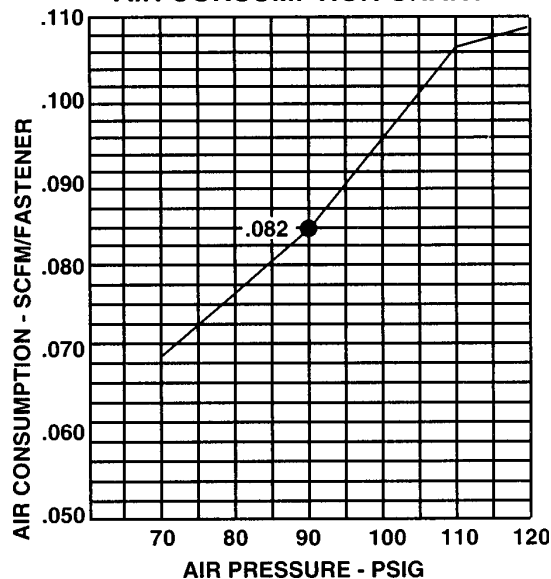

Note: For optimum performance Paslode recommends the use of a 3/8" Male fitting.

PowerMaster Plus™

F-350S
501000

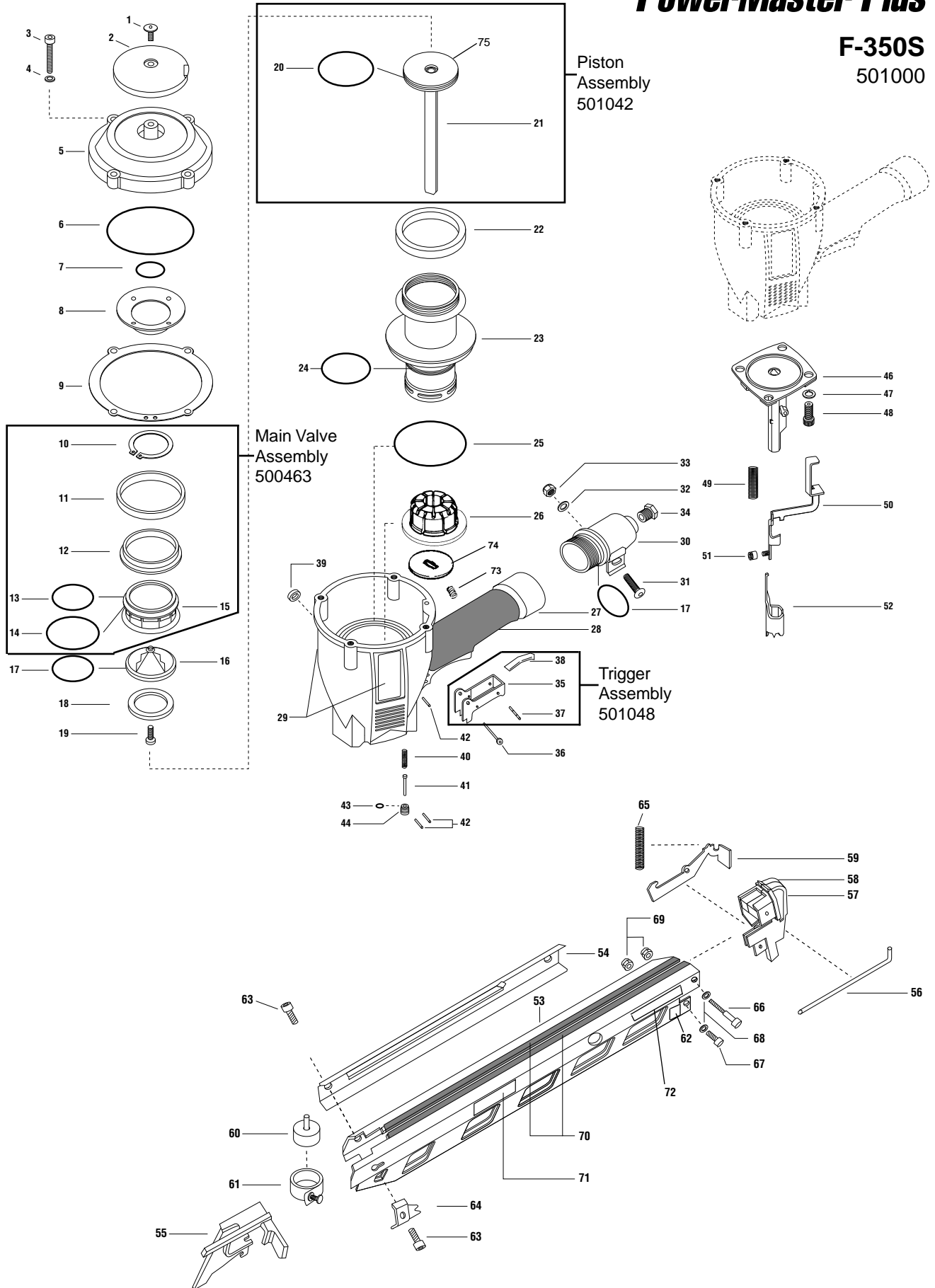

ACCESSORIES

Sequential Operating Kit

This special attachment is designed for sequential operation (stops "contact" firing). The operator must depress and hold the work contacting element against the work surface before pulling the trigger. This sequence must be repeated each time the tool drives a fastener.

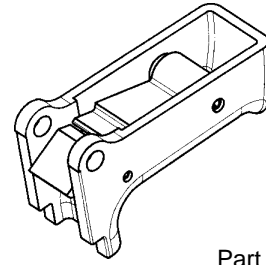

Part No.501039

Remote Fire Valve

This valve via a positive air signal allows a machine mounted tool to be operated from an automatic air valve or foot pedal system.

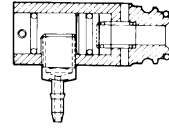

Part No. 1X0713

Adjustable No-Mar Tip Kit

Prevents you from marring wood surfaces. Kit includes an extra rubber tip. (Replacement Rubber Tip only - Part No. 501022)

Part No. 219228

Hanger Kit

Allows you to hang tool from rafters.

Part No. 501049

Cap Hanger Bracket

Attaches to the top of tool for storage or counter-balancing.

Part No. 1X0856

Tool Repair Kit

Repairs cap air leaks, lack of power, skipping and/or sluggishness.

Part No. 219235

Trigger Valve Kit

Repairs trigger valve air leaks.

Part No. 219224

Lubricants and Loctite

Loctite 242 (Blue)

Part No. 093500

Lubricating Oil 8 oz.

Part No. 219026

Lubricating Oil with Antifreeze

Part No. 219090

Chemplex 710 Lubricant 1 lb.

Part No. 403734

Lubricant 5 gram tube

Part No. 219188

Degreaser Cleaner

Ideal cleaner for all Paslode tools.

Part No. 219086

Safety Glasses

Clear

Part No. 402510

Tinted

Part No. 402512

SAFETY INSTRUCTIONS

WEAR EYE AND HEARING PROTECTION



Always wear hearing protection and eye protection devices, including side shields when operating or working in the vicinity of a tool.

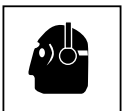

Never use any bottled air or gases such as oxygen to operate the tool since they could cause the tool to explode.

DO NOT EXCEED MAXIMUM RECOMMENDED AIR PRESSURE

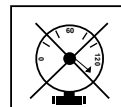

Operate the tool using only the recommended air pressure. Do not exceed the maximum air pressure marked on the tool. Be sure the air pressure gauge is operating properly and check it at least twice a day.

