

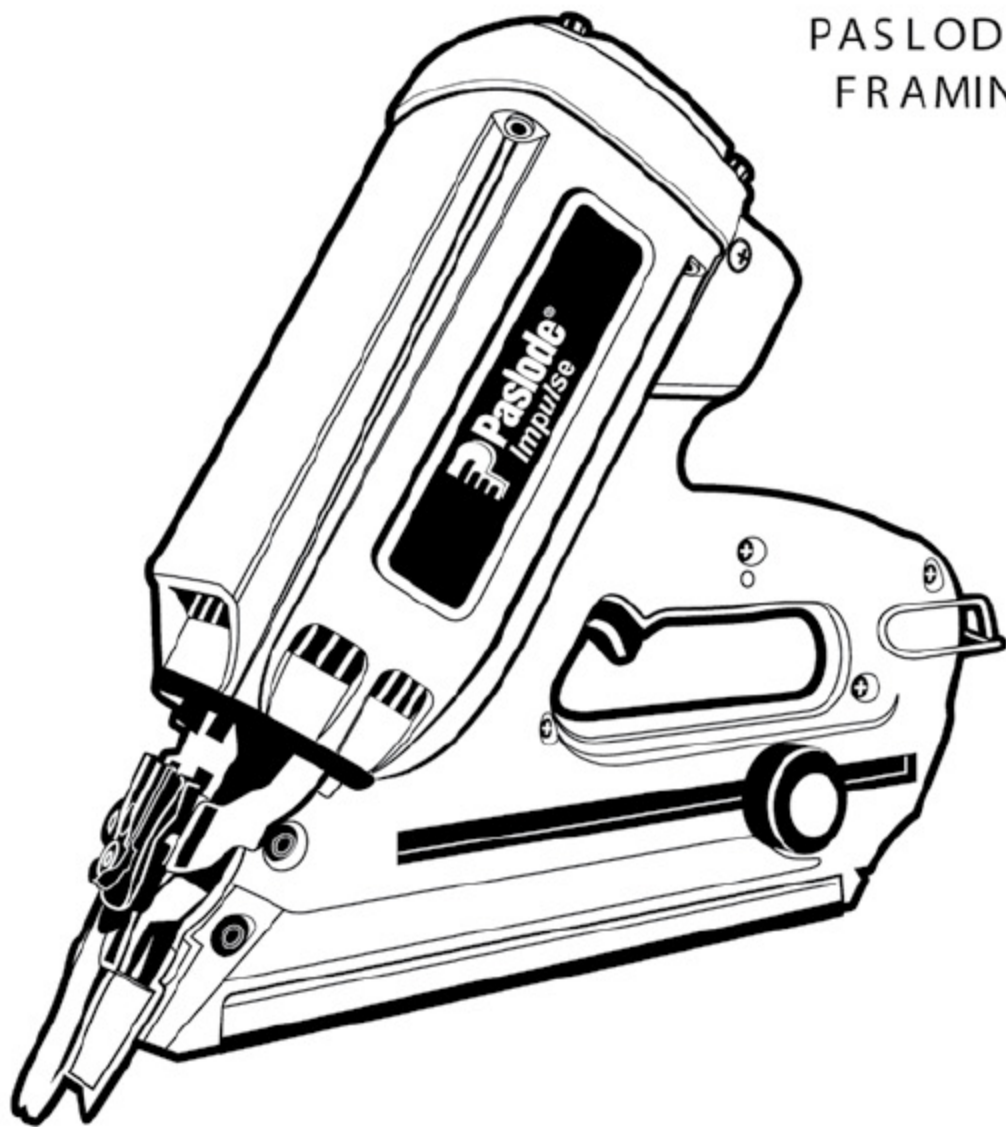

Part. No. 085000 (E.U.)

Part. No. 085010 (U.K.)



## PASLODE IMPULSE FRAMING NAILER

### TOOL SCHEMATIC AND PARTS

#### **IMPORTANT!**

#### **DO NOT DESTROY**

Always refer to operating manual for detailed information on this tool. It is the customer's responsibility to have all operators and service personnel read and understand this information.

# PARTS LEGEND Paslode Impulse FRAMING NAILER, 085000 085010

1	900320	1	Grill	51	404827	2	Pin
*2	900315	1	Filter	*52	404419	1	Bumper
→3	900469	1	Fan Motor Assembly (Includes PC board, washer and flat retaining ring)	53	404411	3	Spring
4	900300	1	Retaining Ring (flat)	54	900934	2	Steel Ring, Sleeve
6	900470	1	Motor Mount	55	901204	1	Sleeve Assembly
7	401355	1	Retaining Ring (curved)	56	404464	2	Rubber Stop
8	901063	4	Shoulder Screw 10-24 x 1-1/2	57	404424	1	Reed Valve
*10	401356	1	Motor Sleeve	58	404422	1	Muffler
11	900286	1	Spark Plug Assembly, includes O-Ring	59	404423	1	Muffler Cover
12	404428	2	Push Rod	■ 61	900596	6	Screw Thread Forming Sems 8-32 x 7/16
13	404453	1	Bracket, Cylinder Head	▲ 62	013681	2	Socket Head Capscrew 10-24 x 1-1/8
14	404432	1	Bushing, Actuator	63	013682	2	Bushing, Shear Block
15	404444	1	Actuator	64	900975	1	Wear Plate, Nose
16	404433	1	Actuator Pin	65	901249	1	Upper Probe
17	401340	1	Stem Adapter	66	901239	1	Lower Probe
18	900471	1	Cylinder Head Machined	67	900592	2	S.H.C.S. Sems 10-32 x 1/2
*19	403992	1	O-Ring	68	401380	1	Tie Bar
20	403167	1	Fan Blade Assembly	70	404704	1	Housing Assembly
→ 21	900474	1	Spark Unit Assembly	71	901251	1	Utility Hook Assembly
22	013676	1	Molded Circuit Assembly	72	013670	2	Label
23	900478	1	Spark Plug Contact Assembly	73	900980	1	Retainer Ring, Sleeve
24	900231	1	Clip, ESU Wire	74	900593	3	S.H.C.S. Sems 10-24 x 5/8
25	403987	2	Screw Thread Forming 6-32 x 1/4	75	403985	1	Follower
26	013675	1	Handle Assembly Kit - Right & Left	76	900520	1	Follower Bushing Spring Assembly
27	013680	1	Roller Lever Assembly	77	901202	1	Retaining Ring
29	404702	2	Screw Thread Forming 6 x 3/8	78	403986	1	Spring Pin
30	404436	1	Nail Channel	79	403984	1	Follower Guide
31	404441	1	Cover Plate Magazine	80	900297	1	Follower Button
32	901222	2	Shoulder Screw 10-32 x 1/2	81	404457	1	Spring
33	900465	1	Cap	82	404922	2	Pad, Battery Contact
34	404412	1	Wear Plate, Chamber Lock	83	401450	5	Fuel Cell Pad
35	900453	4	Screw Plastite 8-16 x 7/8	85	901240	1	Probe Stop
** 36	013671	1	Warning Label	86	404426	1	Exhaust Baffle
37	404442	1	Channel Magazine	87	404425	1	Reed Plate
▲ 38	900594	4	S.H.C.S. Sems 8 - 32 x 1/2	88	900969	4	Torx Screw 8-32 x 5/8
39	901241	1	Spacer	89	900481	1	O-Ring
40	404451	1	Lockout Bar, Follower	**90	013672	1	Warning Label
41	901203	1	Shear Block	91	900372	1	Combustion Chamber Ring
42	901238	1	Spring, Flat	92	404407	1	Combustion Chamber
44	404435	1	Trigger	■ 93	900595	2	Torx Screw Sems 8-32 x 3/8
45	900269	1	Chamber Lock Bar	95	013673	1	Nameplate
46	404927	1	Spring, Trigger	96	900427	1	Light Pipe
47	401328	1	Retainer ring	97	900468	1	Washer, Motor Shaft
48	401461	2	Piston Ring	99	900546	1	Brass Insert
49	404485	1	Piston Assembly	100	900597	4	Screw Thread Forming Sems 6-19 x 3/8
50	900521	1	Combustion Chamber Assembly				

- \* Denotes normal wear items
- \*\* Make sure Warning Labels (013671, 013672) are properly affixed. Replace if necessary. Label is available at no charge through the Service Department.
- ▲ Apply Loctite 242 (Blue) Part No. 093500.
- Apply Loctite RC-620 (Green) Part No. 401491
- Denotes new change.

## SAFETY INSTRUCTIONS

### WEAR EYE AND HEARING PROTECTION



Always wear hearing protection and eye protection devices, including side shields when operating or working in the vicinity of a tool.

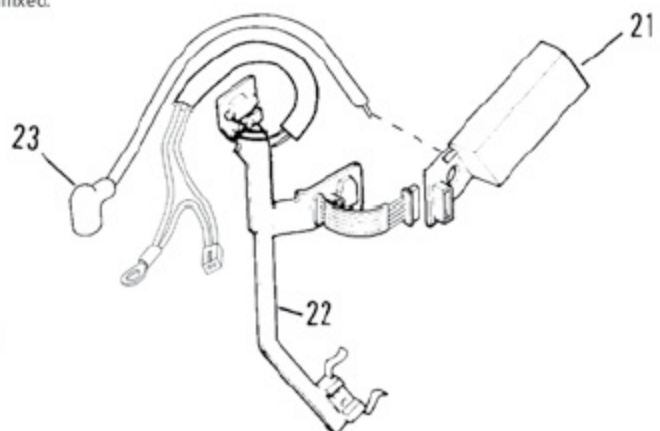

### ▲ WARNING

All parts must be periodically inspected and replaced if worn or broken. Failure to do this can affect the tool's operation and present a safety hazard.

# IMPULSE FRAMING NAILER,

085000

085010

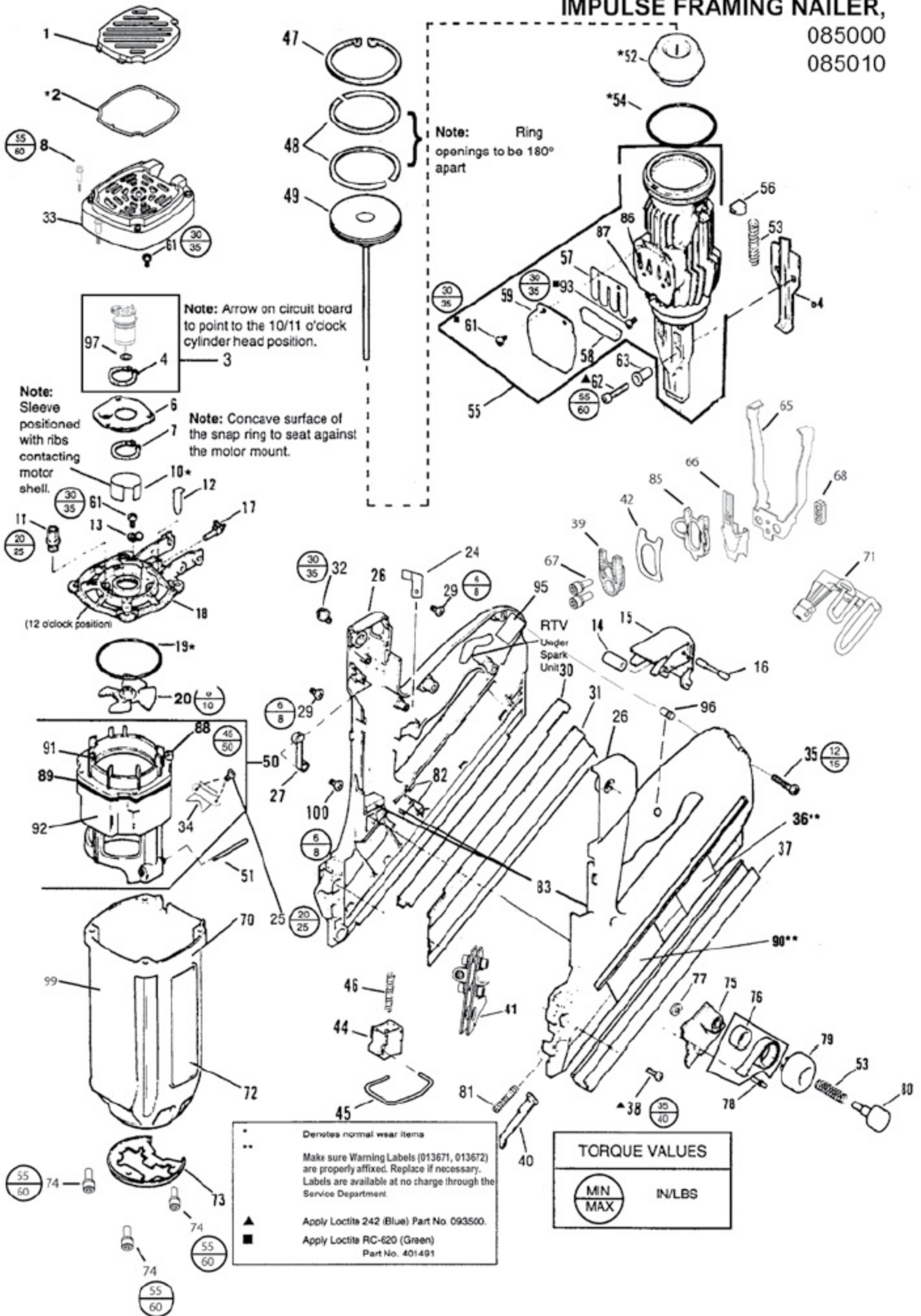

Note: Arrow on circuit board to point to the 10/11 o'clock cylinder head position.

Note: Sleeve positioned with ribs contacting motor shell.

Note: Concave surface of the snap ring to seat against the motor mount.

Note: Ring openings to be 180° apart

RTV Under Spark Unit 30

• Denotes normal wear items  
 •• Make sure Warning Labels (013671, 013672) are properly affixed. Replace if necessary. Labels are available at no charge through the Service Department.  
 ▲ Apply Loctite 242 (Blue) Part No. 093500.  
 ■ Apply Loctite RC-620 (Green) Part No. 401491

TORQUE VALUES	
MIN	MAX
	IN/LBS

## ACCESSORIES

---

### Car Adapter

Enables you to re-charge your battery with your vehicle's electrical system.



Part No. 900507

---

### Battery Cell



Part No. 404717

---

### Paslode Cordless Oil



Part No. 401482

---

### 5/32" Hex Key

For adjusting work contacting element.



Part No. 401331

---

### No-Mar Work Contacting Element

Rubber tipped WCE to eliminate marring work surface.  
(Replacement rubber tip, Part No. 403369)



Part No. 012082

---

### Paslode Cordless Nailer Case

Part No. 404710

---

### Clear Safety Glasses



Part No. 402510

### Orange Safety Glasses



Part No. 011117

### Tinted Safety Glasses

Part No. 402512

---

### Degreaser Cleaner

Ideal cleaner for all Paslode™ tools.

Part No. 115251

---

### Battery Charger Kit

(Replacement Charger Base Only Part No. 035460)

(Replacement Transformer Only Part No. 900477- US/CANADA)



Part No. 900200

(Replacement Transformer Only Part No. 900505 Continental Europe)

(Replacement Transformer Only Part No. 900506 U.K.)

(Replacement Transformer Only Part No. 900504 Australia)

**Paslode®**

Route de Lyon  
B.P. 104  
F-26501 Bourg-lès-Valence

013683  
01/07