

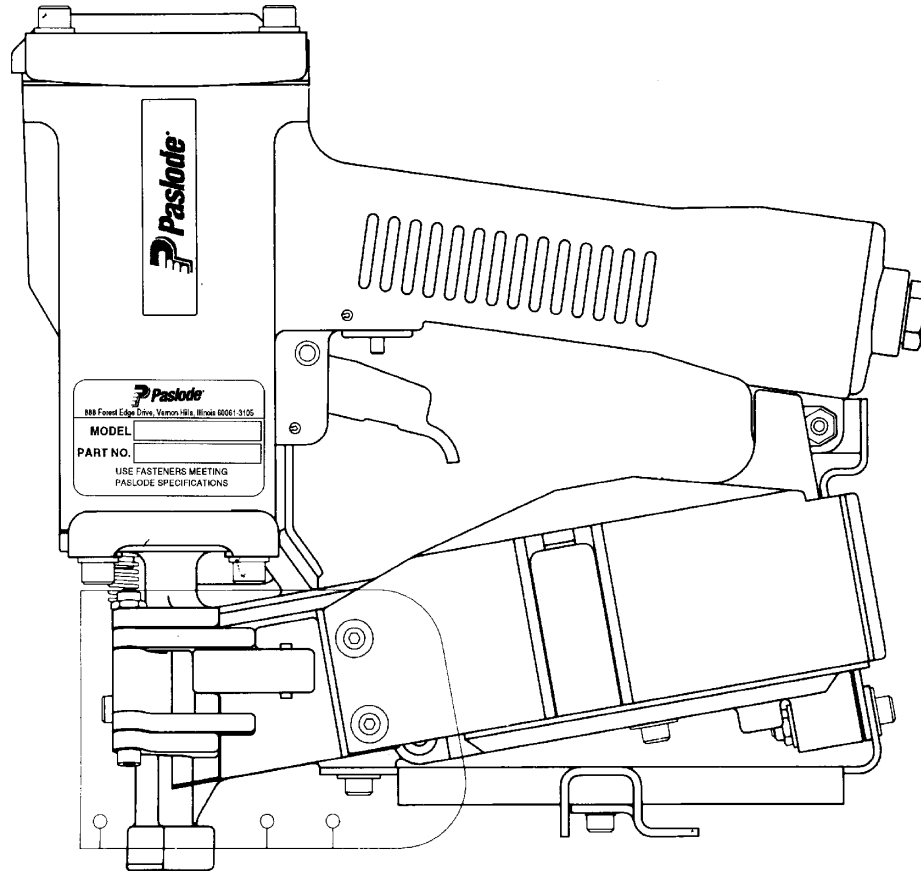

MODEL 3175RCU  
ROOFING COIL NAILER



TOOL SCHEMATIC AND PARTS

**IMPORTANT!**  
**DO NOT DESTROY**

Always refer to safety and maintenance manuals #403606, #405218 and #405220 for detailed information on this tool. It is the customer's responsibility to have all operators and service personnel read and understand this information.

# PARTS LEGEND 3175 RCU, 405000

1	092735	4	Socket Head Capscrew, 1/4-20 x 1-1/4"	50	404012	1	Holdback Claw
2	091447	4	Flat Washer	51	404014	1	Door
3	402726	1	Air Diffuser	52	404013	1	Front Guide
*4	402782	2	Wear Shield Cap	53	404663	1	Spring, Work Contacting Element
▲ 5	006310	1	Socket Head Capscrew, #6-32 x 1/2"	*54	402031	1	"O" Ring
6	402728	1	"O" Ring	55	405234	1	Piston, Feed Claw
7	402704	1	Cap	*56	092709	1	"O" Ring
8	402717	1	Conical Spring	57	096815	1	Spring
9	404230	1	Retaining Ring	58	403572	1	Bumper, Feed Claw Piston
*10	091537	1	"O" Ring, Main Valve Assembly	59	405233	1	Piston Guide
11	404122	1	Upper Valve Piston	60	403573	1	Retaining Ring
12	404055	1	Post, Main Valve	61	402486	1	Retaining Washer
*13	404256	1	"O" Ring, Main Valve Post	▲ 62	009037	2	Socket Head Capscrew, #10-32 x 1/2"
*14	402723	1	"O" Ring, Piston	63	402629	3	Hardened Washer, #10
15	403582	1	Lock Nut, Gripco, 5/16-24	64	404002	1	Grommet, Debris Shield
16	403563	1	Piston	65	404003	1	Intermediate Work Contacting Element
*17	404001	1	Driver Blade	66	402488	1	Pivot Pin, Feed Claw
18	402725	1	Seal, Sleeve	67	402041	1	Torsion Spring, Feed Claw
19	405245	1	Sleeve	68	405001	1	Feed Claw
*20	091966	1	"O" Ring, Sleeve	69	404004	1	Work Contacting Element
*21	402729	1	"O" Ring, Sleeve	**70	400658	1	Warning Label
22	403854	1	Retaining Bumper	71	404015	1	Cover, Magazine
*23	403853	1	Bumper	*72	404092	2	Wear Shield, Magazine
24	402707	1	Gasket, Cap	*73	404093	1	Debris Shield
25	402701	1	Housing	74	403579	1	Roll Pin, 1/16" Dia. x 1/2" Lg.
26	404939	2	Logo, Housing	75	403568	1	Cap, Post
→ 27	096893	1	Nameplate	76	402071	1	Extension Spring, Post
28	402708	1	Gasket, Nose	77	403543	1	Nail Plate Assembly
29	405147	1	Lever, Trigger	78	404731	1	Center Post, Outer
30	405144	1	Trigger	79	403580	1	Retaining Ring
31	500488	1	Grip, Handle	80	403556	1	Center Post, Inner
32	005849	1	Roll Pin	81	005849	2	Roll Pin, 1/8" x 11/16" Lg.
33	402079	1	Pin, Trigger	82	404016	1	Magazine
34	404325	1	Stop Nut	83	404303	1	Socket Head Capscrew, #10-32 x 1 1/4"
35	026133	2	Roll Pin, 1/8" Dia. x 1" Lg.	84	006057	3	Flat Washer, #10
36	404017	1	Magazine Bracket	85	006621	1	Socket Head Capscrew, #10 32 x 7/8"
▲ 37	004502	4	Socket Head Capscrew, #10-32 x 5/8"	86	404019	1	Nut, Shingle Guide
38	092037	9	Flexloc Nut, #10-32	*87	404020	1	Shingle Guide
39	097748	2	Spring	▲ 88	004224	3	Socket Head Capscrew, #10-32 x 3/8"
40	097746	1	Valve Pin	89	404018	1	Bracket, Shingle Guide
*41	092174	1	"O" Ring, Valve Body	90	404361	1	Roll Pin, 1/8" Dia. x 1/2" Lg.
42	401958	1	Valve Body	91	002187	4	Lock Washer, 1/4"
*43	091591	1	"O" Ring, End Plug	92	404054	1	Seal, Main Valve
▲ 44	401940	1	End Plug	*93	090927	1	"O" Ring, Main Valve
45	091622	1	Reducing End Plug	*94	092775	1	"O" Ring, Main Valve
46	404007	1	Nose Assembly With Magnet	*95	092773	1	"O" Ring, Main Valve
47	404106	1	Socket Head Capscrew, #10-32 x 2"	96	404056	1	Lower Valve Piston
48	404091	2	Wear Shield, Nose	97	404010	1	Magnet
▲ 49	091545	4	Socket Head Capscrew, 1/4 - 20 x 7/8"	98	405243	1	Flange, Sleeve

- \*\* NOTE: Make sure Warning Label (400658) is properly affixed.  
 Replace if necessary. Label available at no charge through Service Department.  
 \* Denotes normal wear items  
 ▲ Apply Loctite 242 (Blue) Part No. 093500  
 → Denotes New Change

**AIR CONSUMPTION CHART**

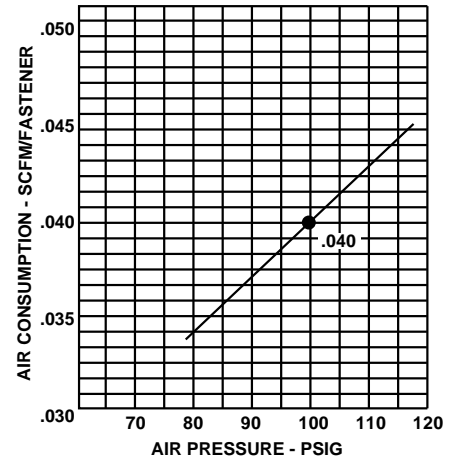

# 3175 RCU

405000

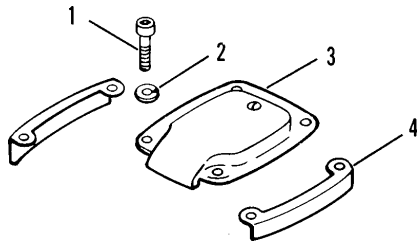

**Cap Assembly  
#402709**

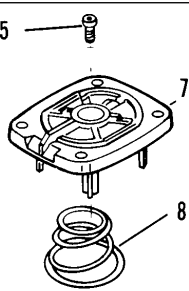

**Main Valve Assembly  
#404188**

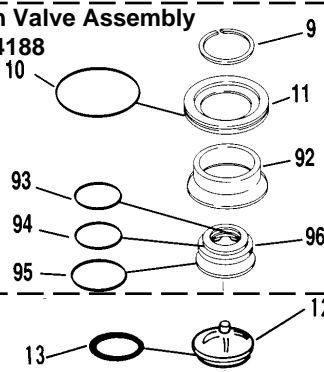

**Piston Assembly  
#404275**

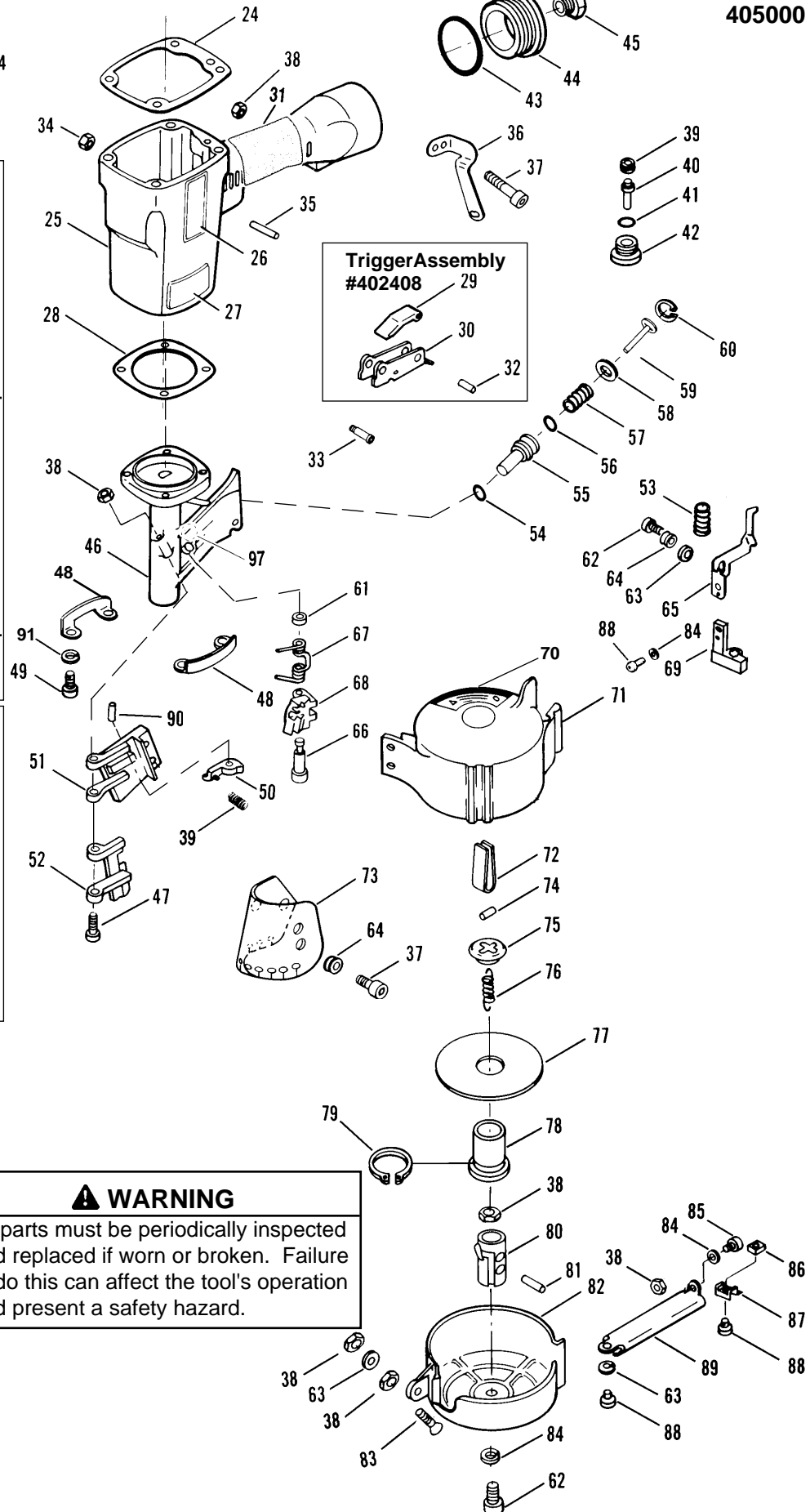
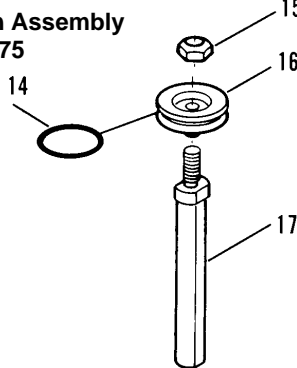

**Trigger Assembly  
#402408**

**⚠ WARNING**  
All parts must be periodically inspected and replaced if worn or broken. Failure to do this can affect the tool's operation and present a safety hazard.

## ACCESSORIES

### Sequential Operating Kit

This special attachment is designed for sequential operation (stops "contact-firing"). The operator must depress and hold the work contacting element against the work surface before pulling the trigger. This sequence must be repeated each time the tool drives a fastener.

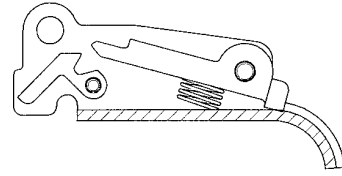

Part No. 406006

### Remote Fire Valve

This valve via a positive air signal allows a machine mounted tool to be operated from an automatic air valve or foot pedal system.

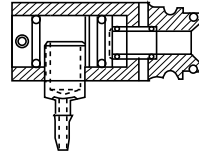

Part No. 1x0713

### Adjustable Work Contacting Element

This adjustable work contacting element has multiple settings to control the depth of drive.

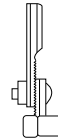

Part No. 1X1374

### Lubricants and Loctite

Chemplex 710 Lubricant (5 gram tube) Part No. 219188  
 Chemplex 710 Lubricant (1 lb.) Part No. 403734  
 Loctite 242 (Blue - 1 oz.) Part No. 093500  
 Lubricating Oil (8 oz.) Part No. 219026  
 Lubricating Oil with Antifreeze (8 oz.) Part No. 219090

### Safety Glasses

Clear Part No. 402510  
 Tinted Part No. 402512

### Tool Repair Kit

This kit repairs all air leaks except for the trigger valve. Part No. 219222

### Degreaser Cleaner

Ideal cleaner for all Paslode tools. Part No. 219086

### Trigger Valve Repair Kit

This kit repairs all trigger valve air leaks. Part No. 219224

### Belt Hook

Attaches to cap of tool enabling you to carry tool on belt holder (offered below). Part No. 219017

### Feeder Claw Repair Kit

This kit repairs nail feed problems. Part No. 219225

### Belt Hook Holder

Attaches to work belt and carries tool using the above belt hook. Part No. 219028

### Large Carrying Case

Handy durable plastic tool case with foam insert that conveniently stores the 3175-R tool, with room for additional accessories. Part No. 219034

## SAFETY INSTRUCTIONS

### WEAR EYE AND HEARING PROTECTION



Always wear hearing protection and eye protection devices, including side shields when operating or working in the vicinity of a tool.

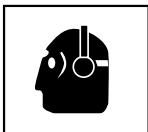

Never use any bottled air or gases such as oxygen to operate the tool since they could cause the tool to explode.

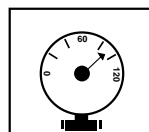
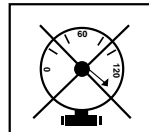

### DO NOT EXCEED MAXIMUM RECOMMENDED AIR PRESSURE

Operate the tool using only the recommended air pressure. Do not exceed the maximum air pressure marked on the tool. Be sure the air pressure gauge is operating properly and check it at least twice a day.



An Illinois Tool Works Company  
 888 Forest Edge Dr.  
 Vernon Hills, Illinois 60061